

1. Product Description

Model Number: Gear Motor, 12GN Series



External appearance will be judged with the naked eye and will be free of scratches and abrasions.

	NA1S	RA1S	NA2S	NA3S	NA4S
Drawing Number	B010348	B010380	B00349	B010350	B010351
Gear Ratio	1/75.7	1/75.7	1/134.5	1/196.6	1/297
		With Limiter			

2. Motor Characteristics

Electrical Characteristics

[Measurement Conditions]

- Motor Configuration: Horizontal output shaft
- Temperature/Humidity: Measurement is, in principle, performed at -10°C~50°C and relative humidity of 30~90%. If in doubt, use the JIS standard temperature state (20°C +/- 2°C, 65% +/- 5%).
- Standard Drive Circuit: LB1836M (Sanyo)

Item	Content	Notes
Rated Voltage	5.0V DC	
Use Voltage	4.0V ~ 6.0V DC	(Across Motor Terminals)
Actuation Current	650 mA +/- 30% (at 5.0V)	
Insulation Resistance	Over 10mΩ with 100V DC applied between the case and the terminals	

	UNIT	NA1S	RA1S	NA2S	NA3S	NA4S	
NO LOAD SPEED	rpm	246	246	134	93	62	+/- 30%
NO LOAD CURRENT	mA	120	120	←	←	←	
200 g - cm LOAD SPEED	rpm	184	184	115	83	58	+/- 30%
200 g - cm LOAD CURRENT	mA	196	196	145	120	95	+/- 30%
STARTING TORQUE	gf - cm	(800)	(800)	(1400)	(2000)	(3300)	
LIMITER ACTION	gf - cm	-	230~600	-	-	-	-

Mechanical Characteristics

Item	Content	Notes
Weight	8.7g +/- 1g	
Rated Load	200 gf-cm (1.96×10^{-2} N · m)	
Motor Configuration	Omnidirectional	
Usage Temperature/ Humidity Range	(0°C ~ +50°C) (20% ~ 90%)	
Storage Temperature/ Humidity Range	(-30°C ~ +70°C) (5% ~ 95%)	
Noise	Below 55 dB at 5.0V	Horizontally mounted with no load. Measured at 30cm from the shaft with a background noise level of below 26 dB-A.
<p>The diagram illustrates the noise measurement setup. A motor is placed on a rectangular sponge cushion that is 3 cm high. A horizontal double-headed arrow indicates a distance of 30 cm between the motor's shaft and the microphone. The microphone is labeled 'MICROPHONE A SCALE' and is connected to a 'NOISE METER RION NA - 23'.</p>		
End Play	0.02 ~ 0.35mm in drive shaft (Shaft Direction)	
Lateral Play	Less than 0.04mm at the tip of the drive shaft	
Vibration	Less than 40m/s^2	V = 6.5V, (between the motor terminals)

Reliability

Measurement Conditions

- Motor Position: Gear Head Horizontal
- Power Supply: Regulated DC Power Supply
- Temperature/Humidity: (15°C ~ 30°C) (30% ~ 90%) RH

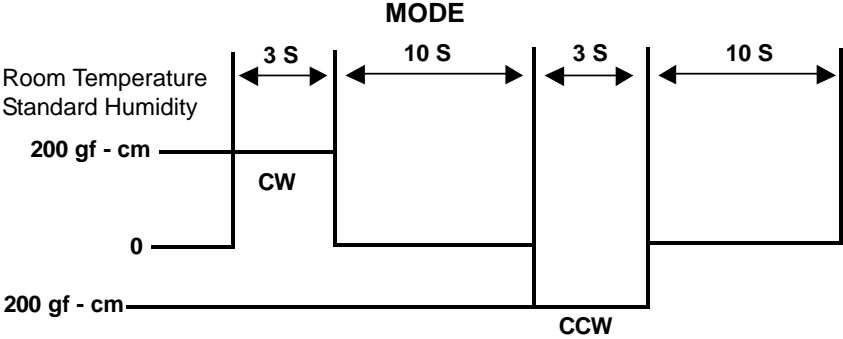
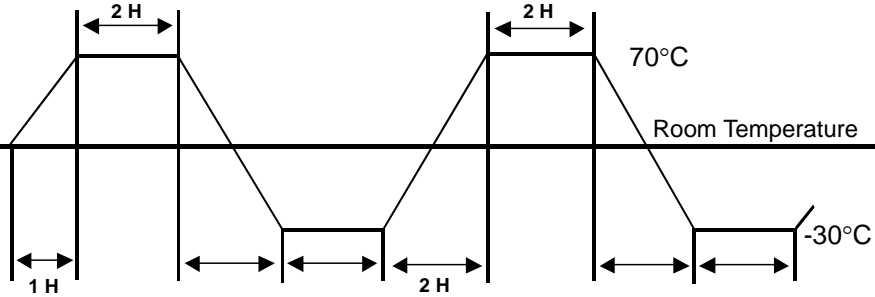
Item	Conditions/Test Environment	Determination Standard
Operation Lifetime Testing	<p> -10°C: 20,000 rotations Room Temperature: 30,000 rotations 50°C: 20,000 rotations Operation. Filter: Open Closed Assumes a 2 second rest. </p>  <p> After 30,000 operating cycles, should be within +/- 50% of the 200 g-cm rated current </p>	<p> Perform testing at the conditions at left with the actual device provided by Sanyo. After testing, the determination standards table should be satisfied. </p>
Temperature Cycling Test	<p> Motors should meet the requirements of section 2 Electrical Characteristics after being held at room temperature for 24 hours of the test below. </p> 	<p> Should satisfy the determination standards table under the environment at left. </p>
Vibration Testing	<p> Acceleration of 3G on motor unit only, frequency of 5 ~ 500 Hz of sinusoidal vibration in vertical direction for 30 minutes each. Must satisfy section 4 and 5 of this specification. </p>	<p> Should satisfy the determination standards table. </p>



Specifications: Gear Motor, 12GN Series

Item	Conditions/Test Environment	Determination Standard
Drop Testing	6 drops, one on each face of mass production packaging from 50 cm. Meet section 4 and 5 after drop test.	Should satisfy the determination standards table.

Reliability Determination Standards Table

Reliability Item		1 Operation Lifetime Testing	2 Thermal Shock Test	3 Low Temperature Testing	4 High Temperature Testing	5 Humidity Resistance Testing	6 Temperature Characteristics Testing	7 Vibration Testing	8 Drop Testing	9 Solder Temperature Resistance
Number	Characteristic Item									
7	Pull-in Torque	○	○	○	○	○	○	○	○	○
1	Coil Resistance	○	NA	NA	NA	NA	NA	NA	NA	NA
3	Insulation Resistance	○	NA	NA	NA	NA	NA	NA	NA	NA
8	Maximum Response Frequency	○	○	○	○	○	○	○	○	○
9	Maximum Actuation Frequency	○	○	○	○	○	○	○	○	○

*Note: Reliability Determination Standard 1 is determined by 5 samplings where AC = 0 and RE = 1.

3. Packing Specification

Motor Tray: 100 pcs per tray

Outside Box: size of figure 1

Motors per package: 100 pcs x 10 trays = max 1000 pcs

In it one piece of cardboard will be placed in the tray for protection.

One empty tray will be taped on top for protection

- Total weight about 9 kg
- 100 pcs per tray
- Part number and number of parts to be noted on the side of the box

External Package: W Carton

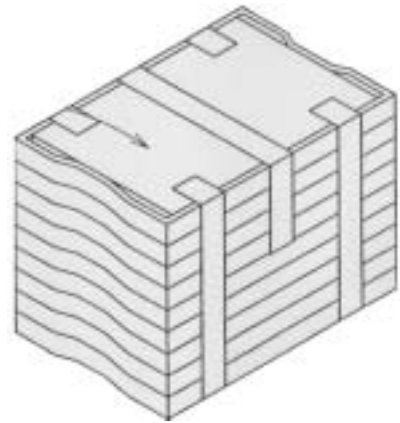
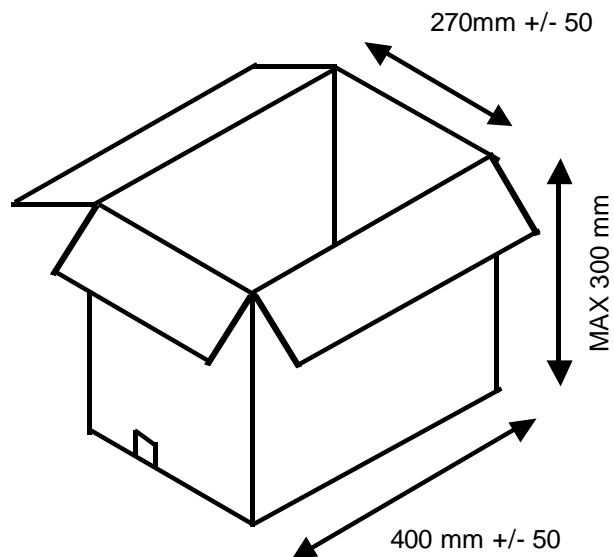

FIGURE 1



4. Other

4-1 Please heed the attached motor handling instructions.

Locking the output shaft during operation may cause destruction of the gears.

There may be modifications to this specification to accommodate improvements in the manufacturing process or motor characteristics.

If there are any questions about a portion of this specification, they may be addressed in a meeting with a representative from Sanyo.

Code	History	Date	Name
△	Print Position Change Version Number 00-01	00.11.02	Morikei
△	Rotation Direction Change Version Number 01-02	01.04.25	Morikei
△	Addition Version Number 02-03	01.08.01	Morikei

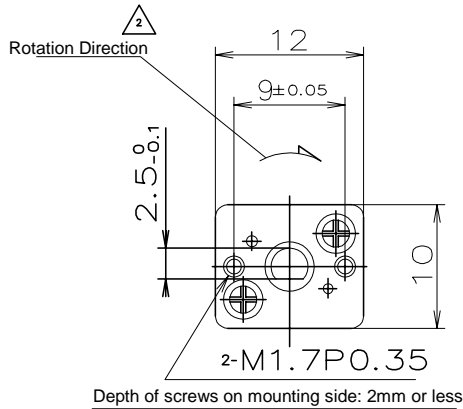

- Note)**
- *1: The pull-out strength after tightening the gearbox plate with the motor mounted is MIN 15kg.
 - *2: The plate is Tuffride processed.
 - *3: The rotation direction of the output shaft should be the direction shown in the figure when + is connected to the + terminal shown in the figure.
 - *4: Soldering work on the terminal should be performed within 2 seconds at 300°C.

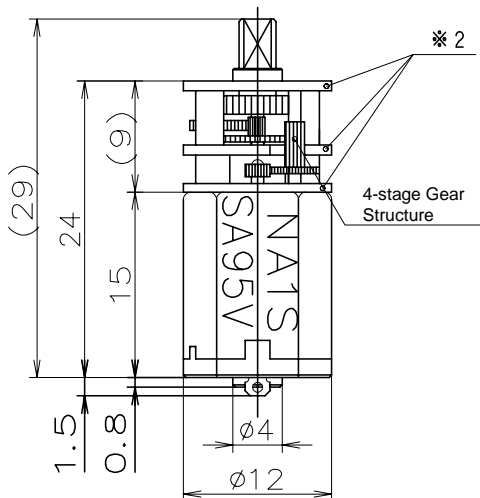

Device Name: NA1S
Lot No. SA95V
SA: Classification Code
9: Last number of western calendar year
5: Month (Oct. Nov. Dec.) = (X, Y, Z)
V: Day (1, 2, 3...9)
 (10, 11, 12.....31) = (A, B,V)

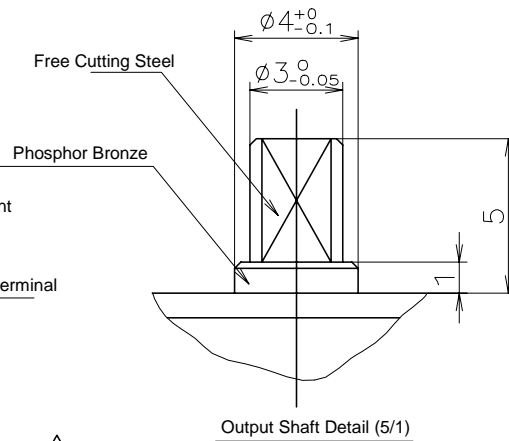
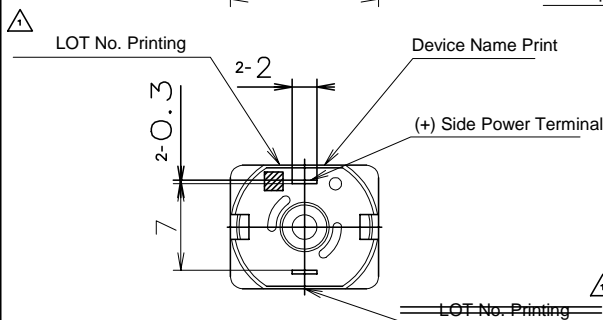

Gear Ratio		1 / 75.7		User Code		-								
Device Name		1 2 G N - A 1 S		User Code		-								
Dimetric Projection	Scale	General Tolerances	Parts List Number	External Drawing of Motor										
	2 / 1	± 0 . 2 5	-											
1999.05.31														
Designed Engineering 99.05.31 Aoki	Drafted Engineering 99.05.31 Sugimura	Checked Engineering 99.06.21 Aoki	Reviewed Engineering 99.06.21 Aoki	Approved Engineering 99.08.19 Nakayama	Parts Code	B	0	1	0	3	4	8	0	3

CHARACTERISTIC - TORQUE SPEED CURRENT
 EXAMPLE CHARACTERISTICS
 T - N . I CURVE - 12GN - A - S

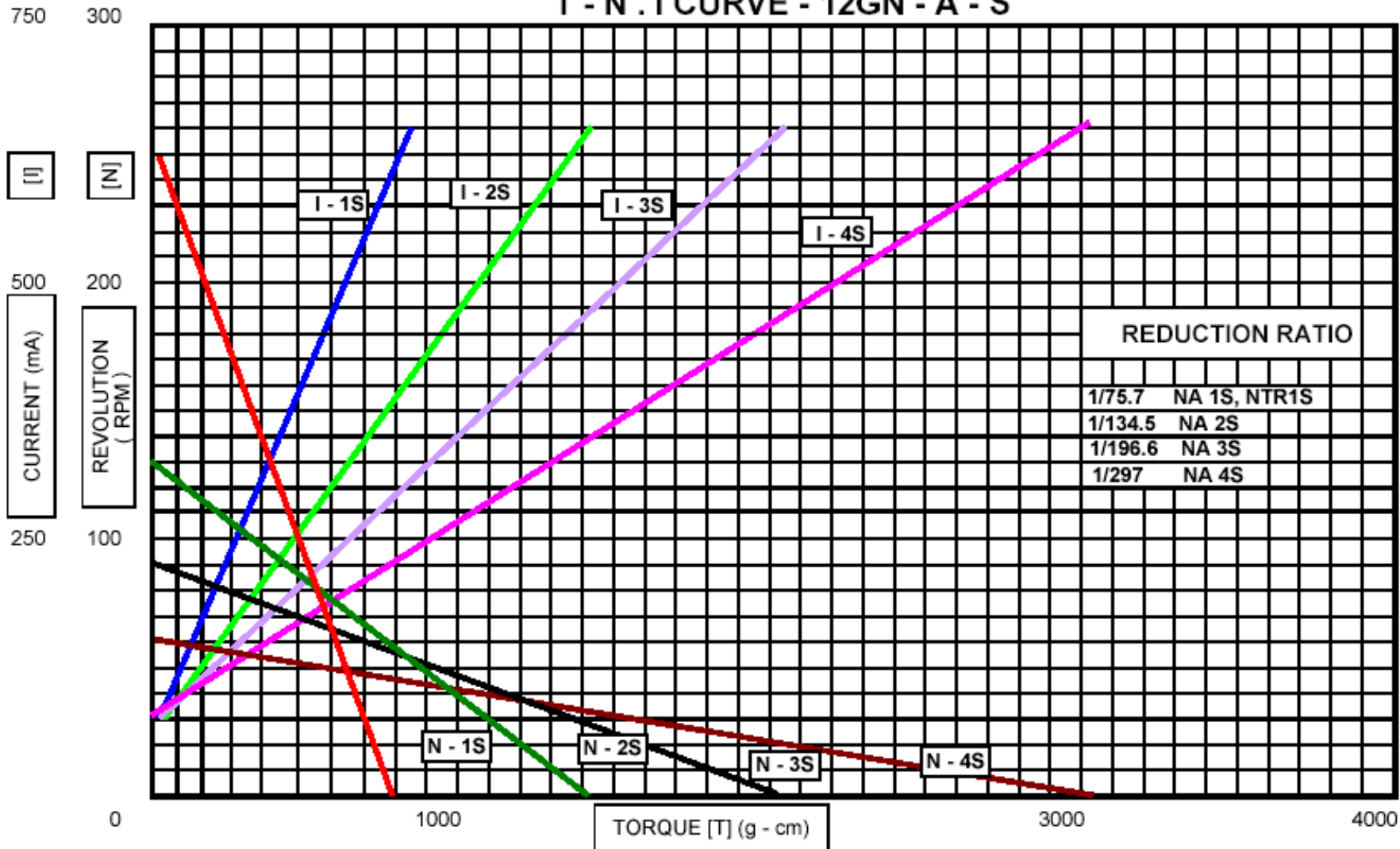

DATE : 1999.06.07
 TEMPERATURE Celsius
 MODEL: 12GN Series
 TYPE: 12GN - A - S
 VOLTAGE: 5V

Cautionary Items on Motor Handling

1. The low-molecular silicone compounds contained in silicone products can lead to contact failures. Exercise sufficient caution when using silicone products.
2. When using adhesives or sealant, etc., take sufficient care that gases harmful to the motor are not generated. Pay particular attention to cyanide adhesives and sulfur gases, etc. In addition, when using adhesives in the mounting of the motor, take care that the adhesive does not flow to the inside of the motor (especially the bearings).
3. The ambient temperature and humidity affect the performance and operational lifetime during motor use. In addition, do not store the motor in a location with high temperature, high humidity, or corrosive gas.
4. The motor drive power source and the drive format can affect the operational lifetime of the motor. Special attention is necessary during pulse driving. In addition, check whether the usage state is at low or high temperatures, rather than normal temperatures.
5. The operational lifetime of the motor may be affected by the application of excessive radial load to the motor by eccentric camming, or in conditions where external vibrations are applied. Check based on the actual usage conditions.
6. If a thrust load such as a worm gear, etc., is applied, the operational lifetime of the motor may be effected. Check based on the actual usage conditions.
7. When a pulley or pinion gear, etc., is impressed on the output shaft, properly impress the opposite shaft end or shaft bearing plate. In addition, if the press-in force is written down, impress within that range.
8. Carefully perform soldering of the motor terminals so as not to apply force which would press-in or deform the motor terminals, or deform the plastic of the terminal mounting, etc.
9. Take particular care that no flux or solder particles scatter into the inside of the motor through the print holes of the end cover. In cases where there is a danger of entrance, take measures such as covering holes close to the terminals. In addition, take sufficient care on amount and type of flux so that it does not flow in along the terminals.
10. Take care not to lock the output shaft with the power ON. Even a short interlock period risks fire, depending on the motor specifications.

Cautions on Safety

1. Be aware that touching the shaft at startup or during operation can cause injuries or burns in high-torque motors, and shaft-machined motors (D cut, grooves/holes, knurling, etc.).
2. In geared motors with exposed gears, be aware not to place hands, etc., near the motor during operation as there is a risk of hands, etc., getting stuck in the gears.
3. Shaft interlock, interterminal shorts or open terminals may occur when the motor is used beyond the warranty period or speed in the specifications due to wear in the structural parts of the motor. Provide a protection means for short current prevention (fuse, etc.) on the unit side.
4. Fully study the motor mounting plate and the materials and ventilation surrounding the motor as these can greatly affect the temperature rise of the motor.
5. The usage environment and usage methods are assumed to be as per the normal range of activity. Sufficient checks are necessary for use in special environments.